



BOATHANDLING SYSTEMS

SWEDEN



NEW  **SWEDISH ORIGINAL DESIGN** 

STEEL TOP/RUBBER HULL PROTECTION.
RUBBER GREY EPDM. US-2021-0245850-A1



NEW

LCFg



NEW

LCMg

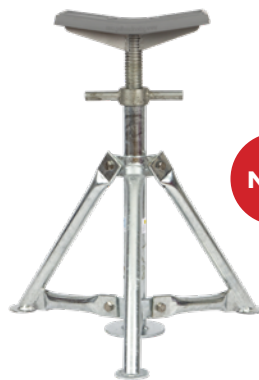

NEW

LCKg





TYRESÖSTÖTTAN

LCFG – Galvanized boat stand

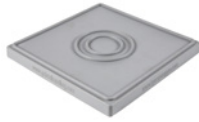

Profiled hull pad of quality rubber – best friction and protection.
210x210x25 mm/8,3x8,3x0,98 Inch

NEW SWEDISH ORIGINAL DESIGN
STEEL TOP/RUBBER HULL PROTECTION.
RUBBER GREY EPDM. US-2021-0245850-A1

Demountable hot-dip galvanized steel stand with integrated quick couplers for safety chain – easy, worry-free installation and maintenance with best operating reliability.

Hot-dip galvanized steel top plate (stainless steel screw/locking nut) with integrated quick couplers for safety chain – easy, worry-free installation and maintenance.

Hot-dip galvanized, trapezoidal threaded rod and winged nut – fast and easy adjustment.



Quick coupler top plate LCFG/LCMG

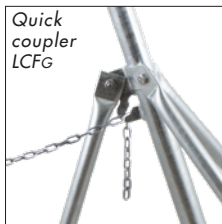

Quick coupler LCFG



Safety Chain, delivered in box



Safety Chain must always be used between the pair of stands



Hot-dip galvanized.



Mitered end.



Delivered disassembled in box.

Type	Max load (kg/lbs)	Height (mm/inch)		Weight (approx. kg/lbs)	Gross weight (approx. kg/lbs)	Box size LxWxH (mm/inch)
		~ min	~ max			
LCFe 80	1500/3306	800/32	1250/49	16/35	17/37	840x240x140/33x9,5x5,5
LCFe 110		1100/44	1550/61	19/41	20/44	1100x240x140/43,3x9,5x5,5
LCFe 130		1300/52	1750/68	21/46	22/48	1300x240x140/51,2x9,5x5,5
LCFe 150		1500/59	1950/76	23/50	25/55	1510x240x140/59,5x9,5x5,5
LCFe 170		1700/67	2150/84	25/55	27/59	1710x240x140/67,3x9,5x5,5
LCFe 190		1900/75	2350/92	28/61	30/66	2110x240x140/83x9,5x5,5
Safety chain	Length ~ 3,05 m/10 foot			1,5/3,3	1,6/3,5	140x140x45/5,5x5,5x1,8

TYRESÖSTÖTTAN

LCMG – Galvanized boat stand



Demountable hot-dip galvanized steel stand with integrated quick couplers for safety chain – easy, worry-free installation and maintenance with best operating reliability.

Profiled hull pad of quality rubber – best friction and protection.
310x160x25 mm/12,2x6,3x0,98 Inch

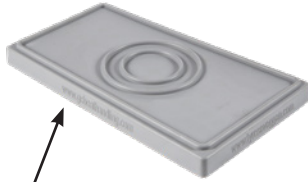

NEW GIC SWEDISH ORIGINAL DESIGN
STEEL TOP/RUBBER HULL PROTECTION.
RUBBER GREY EPDM. US-2021-0245850-A1

Hot-dip galvanized steel top plate (stainless steel screw/locking nut) with integrated quick couplers for safety chain – easy, worry-free installation and maintenance.

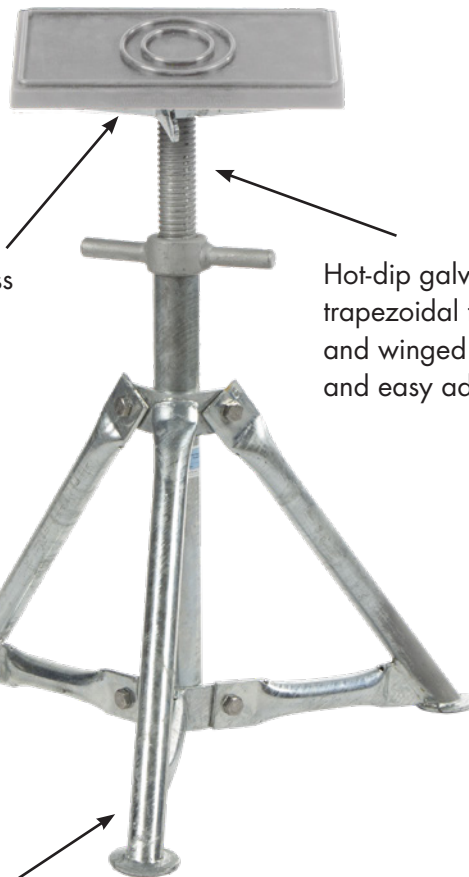

Hot-dip galvanized, trapezoidal threaded rod and winged nut – fast and easy adjustment.

Hot-dip galvanized.



Mitered end.



Delivered disassembled in box.

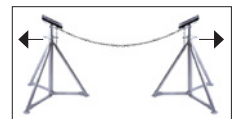

Safety Chain must always be used between the pair of stands

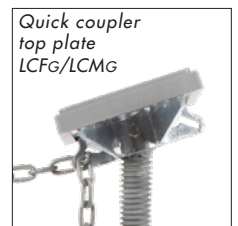

Quick coupler top plate LCFG/LCMG

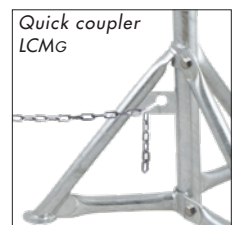

Quick coupler LCMG



Safety Chain, delivered in box

Type	Max load (kg/lbs)	Height (mm/inch)		Weight (approx. kg/lbs)	Gross weight (approx. kg/lbs)	Box size LxWxH (mm/inch)
		~ min	~ max			
LCMG 500	2750/6062	500/20	800/31	12,2/26,9	14,0/30,9	530x410x170/20,9x16,2x6,7
LCMG 600		600/24	900/35	12,6/27,8	14,4/31,8	530x410x170/20,9x16,2x6,7
LCMG 750		750/30	1050/41	15,2/33,5	18,2/40,2	830x500x170/32,7x19,7x6,7
LCMG 900		900/36	1200/47	15,8/34,9	18,8/41,5	830x500x170/32,7x19,7x6,7
Safety chain	Length ~ 3,05 m/10 foot			1,5/3,3	1,6/3,5	140x140x45/5,5x5,5x1,8

TYRESÖSTÖTTAN

LCKG – Galvanized keel stand



Demountable hot-dip galvanized steel stand. Worry-free installation and maintenance with best operating reliability.



Profiled hull pad of quality rubber – best friction and protection.
LxWxH 310x160x25 mm/12,2x6,3x0,98 inch.
Rubber Grey EPDM.

NEW GIC SWEDISH ORIGINAL DESIGN
STEEL TOP/RUBBER HULL PROTECTION.
RUBBER GREY EPDM. US-2021-0245850-A1



Mitered end.



Delivered disassembled in box.

Type	Max load (kg/lbs)	Height (mm/inch)		Weight (approx. kg/lbs)	Gross weight (approx. kg/lbs)	Box size LxWxH (mm/inch)
		~ min	~ max			
LCKG 3	2750/6062	590/23	750/30	12,6/27,8	14,9/32,9	530x500x195/20,9x19,7x7,7
LCKG 4		420/16	580/22	10,7/23,6	12,5/27,6	530x410x195/20,9x16,2x7,7
LCKG 5	5000/11023	540/21	770/30	18,3/40,4	20,1/44,3	530x410x170/20,9x16,2x6,7
LCKG 7		760/30	990/39	22,1/48,8	25,0/55,1	830x500x170/32,7x19,7x6,7

User guide LCFg/LCMg/LCKg

- Boat stands should only be used on firm surface where surrounding conditions (like weather) never affect the stability.
- Position the stands according to the boat manufacturers recommendations, normally a pair of stands for every 8–10 feet (2.6–3.3 meters).
- The entire weight of the boat should be borne by the keel support, not by the stands.
- The keel support should be placed depending on the weight distribution of the boat.
- Never tie anything to the stands (like cover). In heavy wind the stands might be pulled away.
- This users guide should always be followed for best results and safety.

Position the stand with the adjustment screw in as straight 90° angle to the hull as possible.

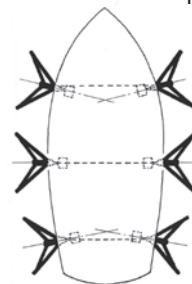
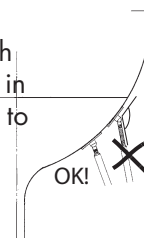

Turn the stand to point towards the center line of the boat.

8–10 feet (2.6–3.3 meters)

LCFg

Safety chain should always be used to secure the stands to each other

- The number of stands is determined by weight, weight distribution and length of the boat.
- Use a wide, large sized block as keel support both in the front and back of the keel.
- An extra pair of stands should be used on a boat with the rig raised.
- Select type of stand to ensure equal adjustment for the Acme thread in both directions.
- Type of stand is determined by:
Draft + height of keel support
– approximately 0.25 m = height of stand.

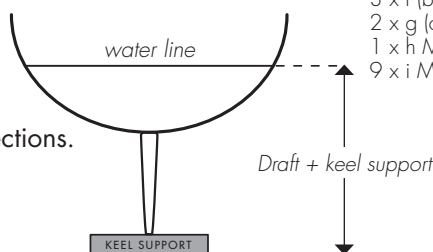

- 1 x a (hull protection)
- 1 x b (hull plate)
- 1 x c (adjusting screw)*
- 1 x d (inner stay)
- 1 x e (mid stay)
- 3 x f (bottom stay)
- 2 x g (outer stay)
- 1 x h M8 x 70 (bolt and nut)*
- 9 x i M12 x 25 (bolt and nut)*

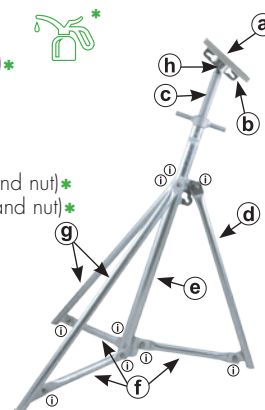

LCMg

Safety chain should always be used to secure the stands to each other

- The type of stand is determined by keel support and shape of the hull. LCM is used for flat bottom. LCF is to be used for all other hull shapes (eg for the bow or sharp V-shaped hulls).
- The number of stands is determined by weight, weight distribution and length of the boat.
- Use LCKg or large sized blocks as keel support.
- Select type of stand to ensure equal adjustment for the Acme thread in both directions.

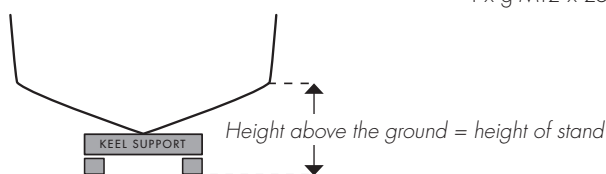

- 1 x a (hull protection)
- 1 x b (hull plate)
- 1 x c (adjusting screw)*
- 1 x d (inner stay)
- 2 x e (mid stay)
- 1 x f M8 x 70 (bolt and nut)*
- 4 x g M12 x 25 (bolt and nut)*



LCKg

- The number of stands is determined by weight, weight distribution and length of the boat.
- Use LCKg or large sized blocks as keel support.
- Select type of stand to ensure equal adjustment for the Acme thread in both directions.

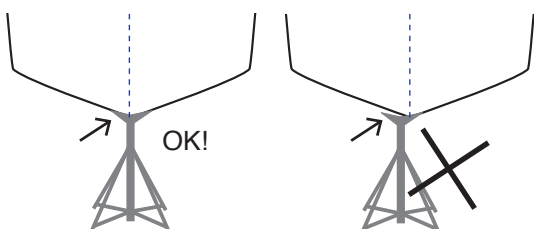

LCKg-3/LCKg-4

- 1 x a (hull protection)
- 1 x b (adjusting screw + V-top)*
- 1 x c (inner stay)
- 2 x d (mid stay)
- 4 x e M12 x 25 (bolt and nut)*

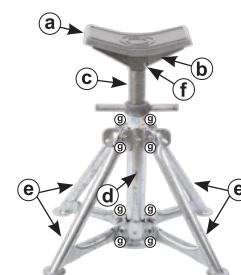
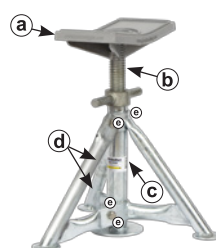

LCKg-5/LCKg-7

- 1 x a (hull protection)
- 1 x b (hull plate)
- 1 x c (adjusting screw* + V-top)
- 1 x d (inner stay)
- 4 x e (mid stay)
- 1 x f M12 x 70 (bolt and nut)*
- 8 x g M12 x 30 (bolt and nut)*

TYRESÖSTÖTTAN

SBS/MBS

Galvanized boat stand

NEW  **SWEDISH ORIGINAL DESIGN** 

STEEL TOP/RUBBER HULL PROTECTION.
RUBBER GREY EPDM. US-2021-0245850-A1

Profiled hull pad of quality rubber
– best friction and protection.
255x255x25 mm/10x10x0,98 inch
Grey EPDM 60 shA

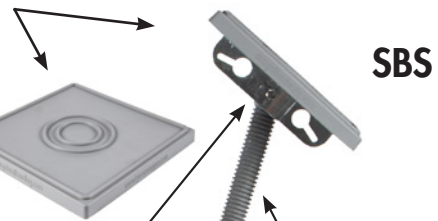

SBS

Profiled hull pad of quality rubber
– best friction and protection.
310x160x25 mm/12,2x6,3x0,98 inch
Grey EPDM 60 shA

Hot-dip galvanized steel
top plate (stainless steel
screw/locking nut) with
integrated quick couplers
for safety chain – easy,
worry-free installation
and maintenance.

Hot-dip galvanized,
trapezoidal threaded rod
and winged nut
– fast and easy adjustment.

MBS

Hot-dip galvanized
steel top plate (stainless
steel screw/locking nut)
with integrated quick
couplers for safety
chain – easy, worry-free
installation and
maintenance.

Hot-dip galvanized,
trapezoidal threaded
rod and winged nut
– fast and easy
adjustment.

Hot-dip galvanized.

Hot-dip galvanized.



Quick coupler
top plate SBS

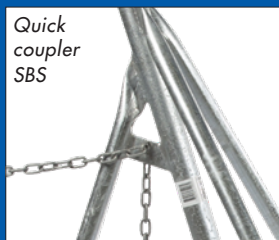

Quick
coupler
SBS



Quick coupler
top plate MBS

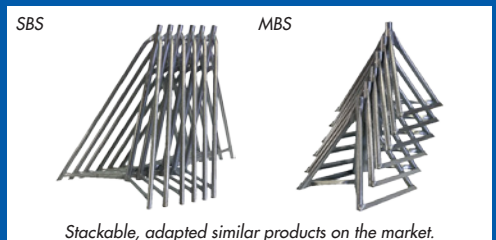

SBS

MBS

Stackable, adapted similar products on the market.

Sailboat/Keelboat

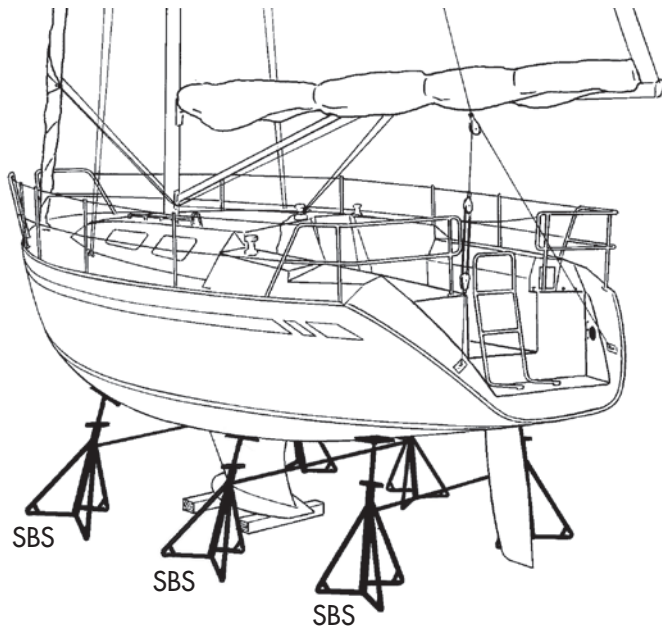

SBS stackable



- The number of stands is determined by weight, weight distribution and length of the boat.
- Use a wide, large sized block as keel support both in the front and back of the keel.
- An extra pair of stands should be used on a boat with the rig raised.
- Select type of stand to ensure equal adjustment for the Acme thread in both directions.
- Type of stand is determined by: Draft + height of keel support – approximately 0,25 m = height of stand.

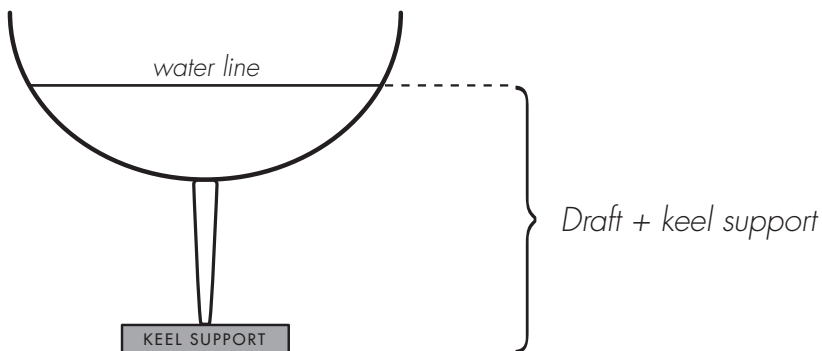

Type	Height of stand (meter) ~	Max load per stand (ton) ~	Weight (kilo)
SBS-4 ²	0,61–0,91	3,6	12,4
SBS-3 ¹	0,89–1,32		16,2
SBS-2 ¹	1,22–1,65		18,9
SBS-1 ¹	1,63–2,06		23,5
SBS-0 ¹	2,01–2,44		26,1
V-TOP	–		16,5
P-STG	–		1,5

Number of stands	Boat length (maximal)
4–6	9 m
6–8	12 m
8–10	15 m
10–12	18 m

1. Rod 27" 2. Rod 23"

Motorboat

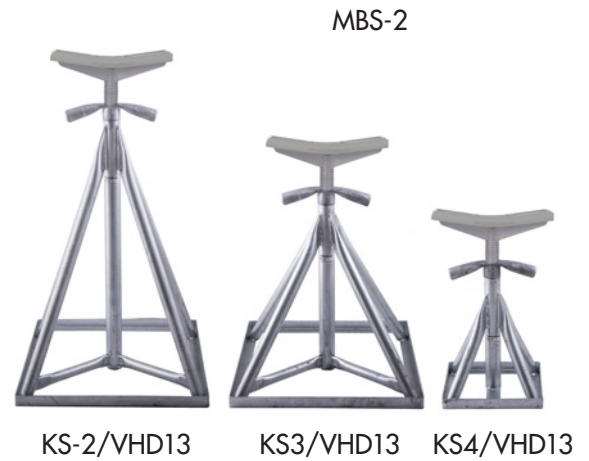
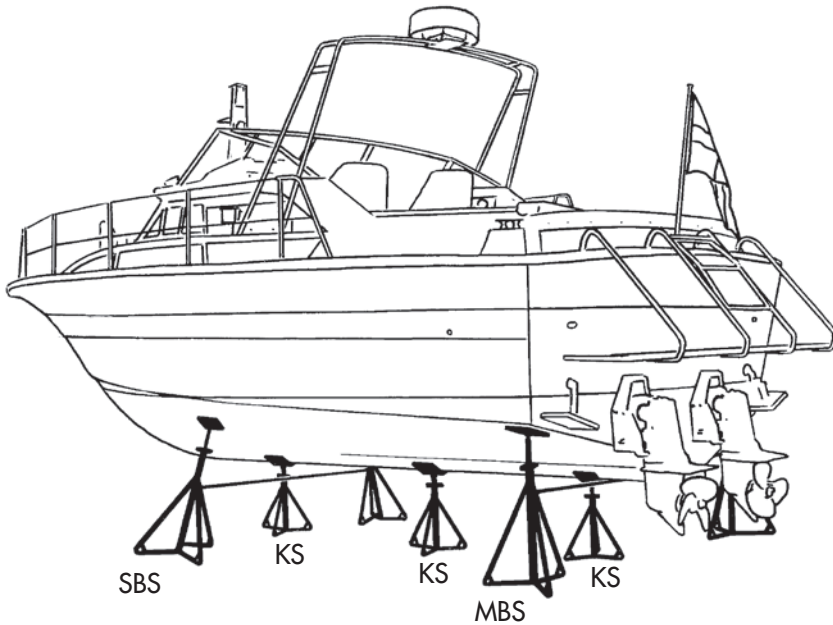

- The type of stand is determined by keel support and shape of the hull. MBS is used for flat bottom. SBS is to be used for all other hull shapes (eg for the bow or sharp V-shaped hulls).
- The number of stands is determined by weight, weight distribution and length of the boat.
- Use KS3, KS4 or large sized blocks as keel support.
- Select type of stand to ensure equal adjustment for the Acme thread in both directions.

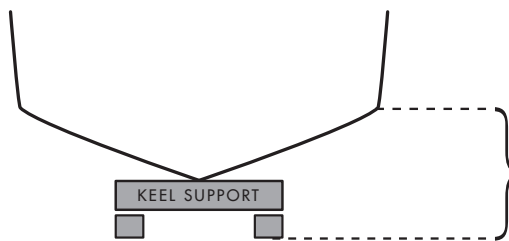

NEW  **SWEDISH ORIGINAL DESIGN** 

STEEL TOP/RUBBER HULL PROTECTION.
RUBBER GREY EPDM. US-2021-0245850-A1

Type	Height of stand (meter) ~	Max load per stand (ton) ~	Weight (kilo)
MBS-4 ^{3,4}	0,46–0,64	3,6	12,7
MBS-3 ²	0,64–0,97		13,4
MBS-2 ¹	0,74–1,17		15,2
MBS-1 ¹	0,84–1,27		15,6
MBS-0 ¹	1,04–1,47		16,0
V-TOP	–		6,5
P-STG	–	1,5	
KS-4 ⁴ /VHD13	0,41–0,61	4,5	9,6
KS-3/VHD13	0,61–0,76		13,0
KS-2/VHD13	0,82–1,10		20,0

Number of stands	Number of stands	Boat length (maximal)
4–6	2–3	9 m
6–8	3–4	12 m
8–10	4–5	15 m
10–12	5–6	18 m

1. Rod 27" 2. Rod 23" 3. Rod 16" 4. Not stackable

User guide

- Boat stands should only be used on firm surface where surrounding conditions (like weather) never affect the stability.
- Position the stands according to the boat manufacturers recommendations, normally a pair of stands for every 2,6–3,3 meter (8–10 feet).
- The entire weight of the boat should be borne by the keel support, not by the stands.
- The keel support should be placed depending on the weight distribution of the boat.
- Safety chain should **always** be used to secure the stands to each other.
- Never tie anything to the stands (like cover). In heavy wind the stands might be pulled away.
- This users guide should always be followed for best results and safety.

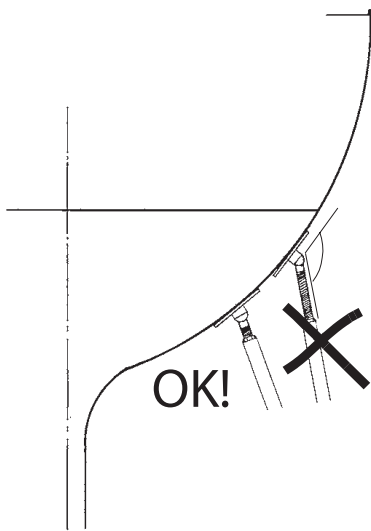

Position the stand with the adjustment screw in as straight 90° angle to the hull as possible.

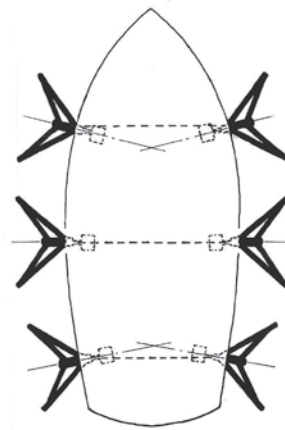

Turn the stand to point towards the center line of the boat.

2,6–3,3 m



SBS



MBS

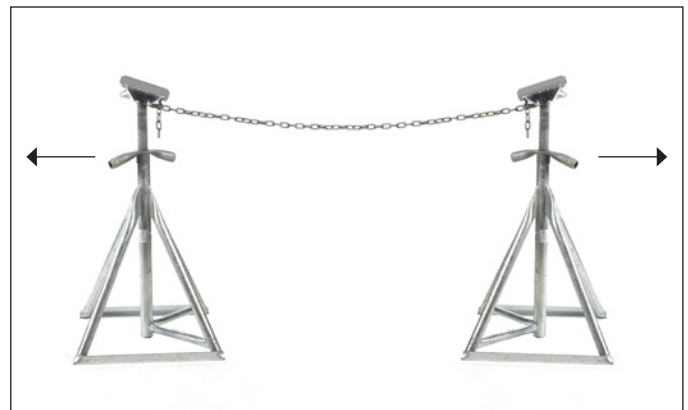

Attach the safety chain according to the pictures above and tighten up by pulling the stand backwards.

UpGrade Kit

NEW  **SWEDISH ORIGINAL DESIGN** 

STEEL TOP/RUBBER HULL PROTECTION.
RUBBER GREY EPDM. US-2021-0245850-A1

Replace your plywood top



UPGRADE KIT SBS/SB/LCF

Hot-dip galvanized steel top plate with profiled hull pad of quality rubber.

255x255x25 mm/10,04x10,04x0,98 inch. Rubber: grey EPDM
Also suitable for MBS/MB/LCM.



UPGRADE KIT MBS/MB/LCM

Hot-dip galvanized steel top plate with profiled hull pad of quality rubber.

310x160x25 mm/12,20x3,60x0,98 inch. Rubber: grey EPDM
Also suitable for SBS/SB/LCF





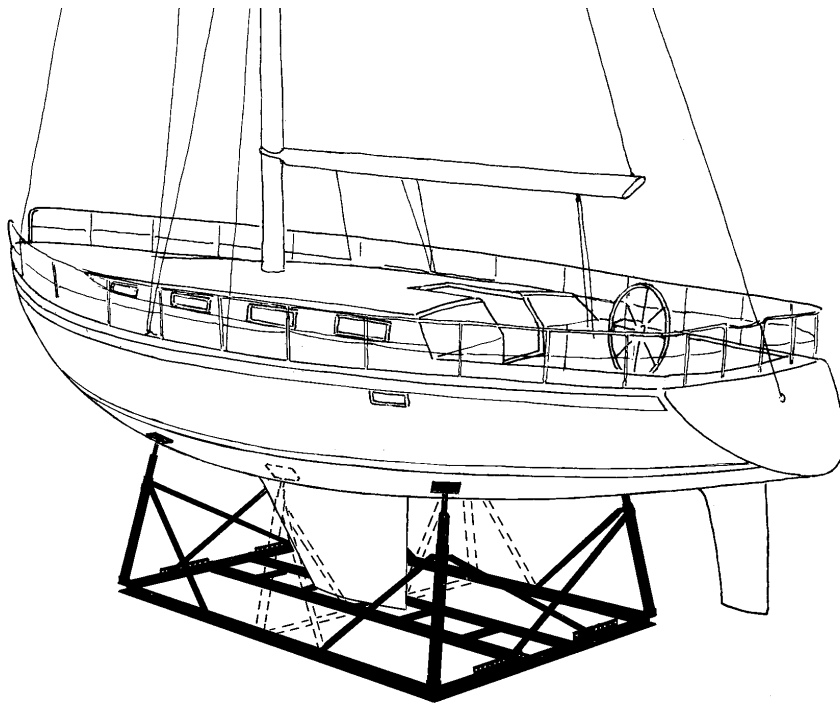

An all-steel cradle suitable for keelboats of max 18 meter length overall. A variety of models are available to fit every kind of boat type.

- **Outstanding stability**
- **A carefully dimensioned bottom frame, equipped with a strong keel ladder, guarantees a reliable shoring up**
- **Easy to dismantle for storage or transportation**
- **Telescopic stands with accurate setting of height and adjustable tilt angle**
- **Ball jointed hull plates (rubber hull protection is include)**
- **All parts are powder coated**

Customized cradles are produced in accordance with individual desires.

*Rubber hull protection
as accessory.*

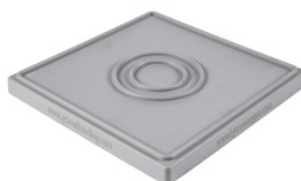

210x210x25 mm
8,3x8,3x0,98 inch
TYPE I, II, III, IV

SteelCradle/TYRESÖVAGGAN

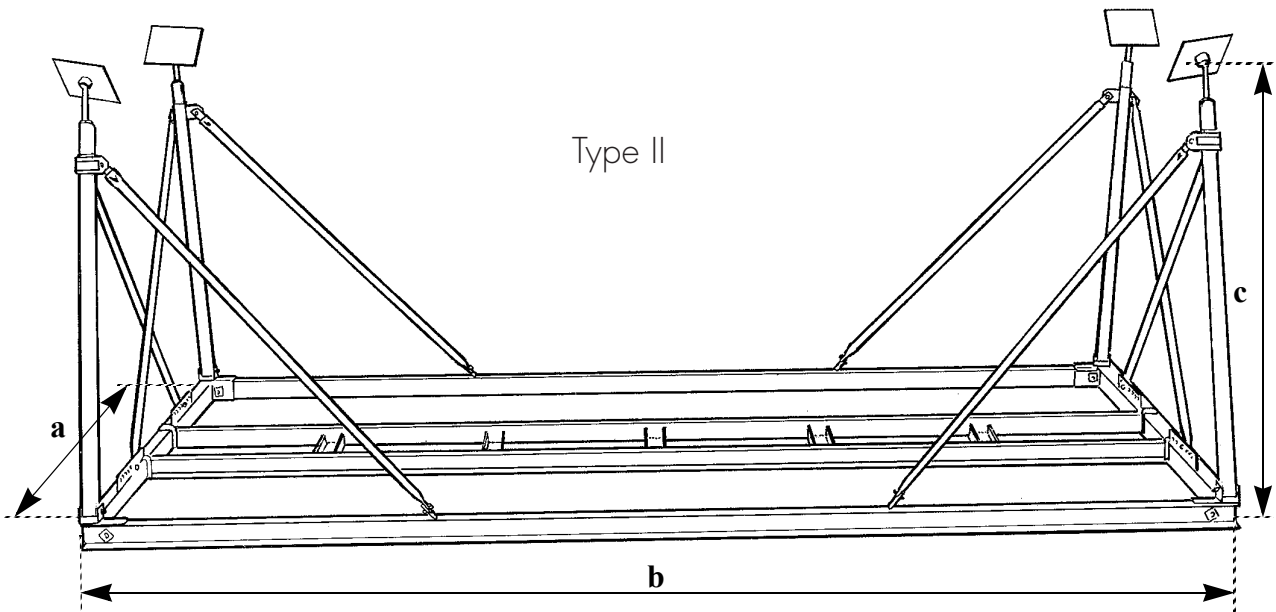
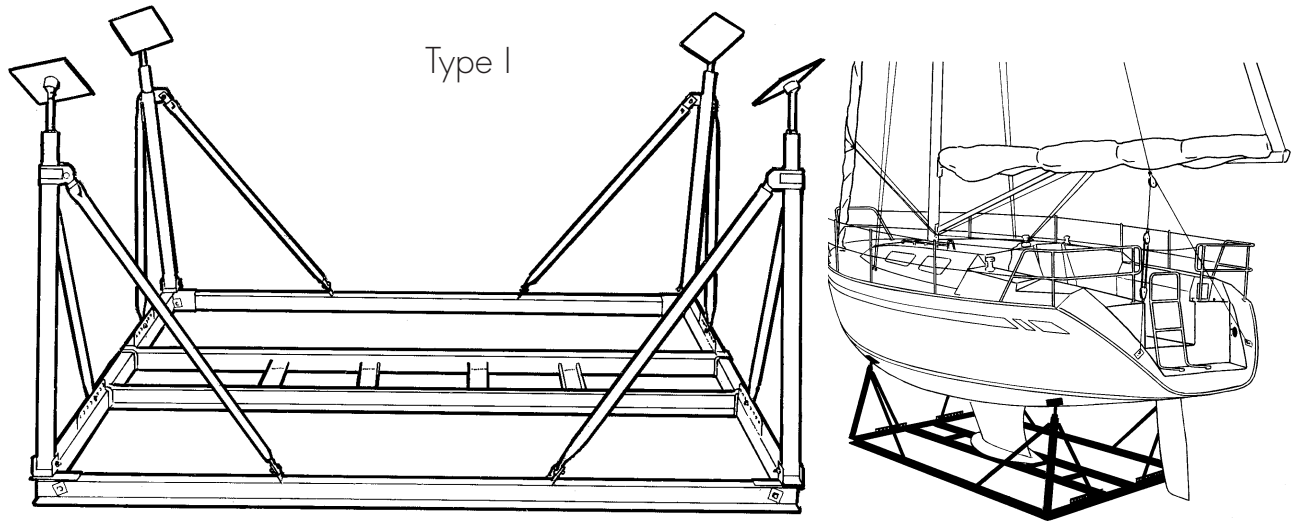

Type	Max load (kg)	Stands (No. of)	Width (a) (m)	Length (b) (m)	Stand height (c) (approx m)	Weight (approx. kg)
I	7000	4	2,2	2,5	0,9-1,4/1,1-1,6	150
				3,0		165
				4,0		180
Extension kit I		+2	2,2	+1,35		60
II		4	2,2	3,0	1,4-1,9	180
				4,0		200
Extension kit II	+2	2,2	+1,35		60	

Type I, II and IV can be delivered in width 2,60 m.

SteelCradle/TYRESÖVAGGAN

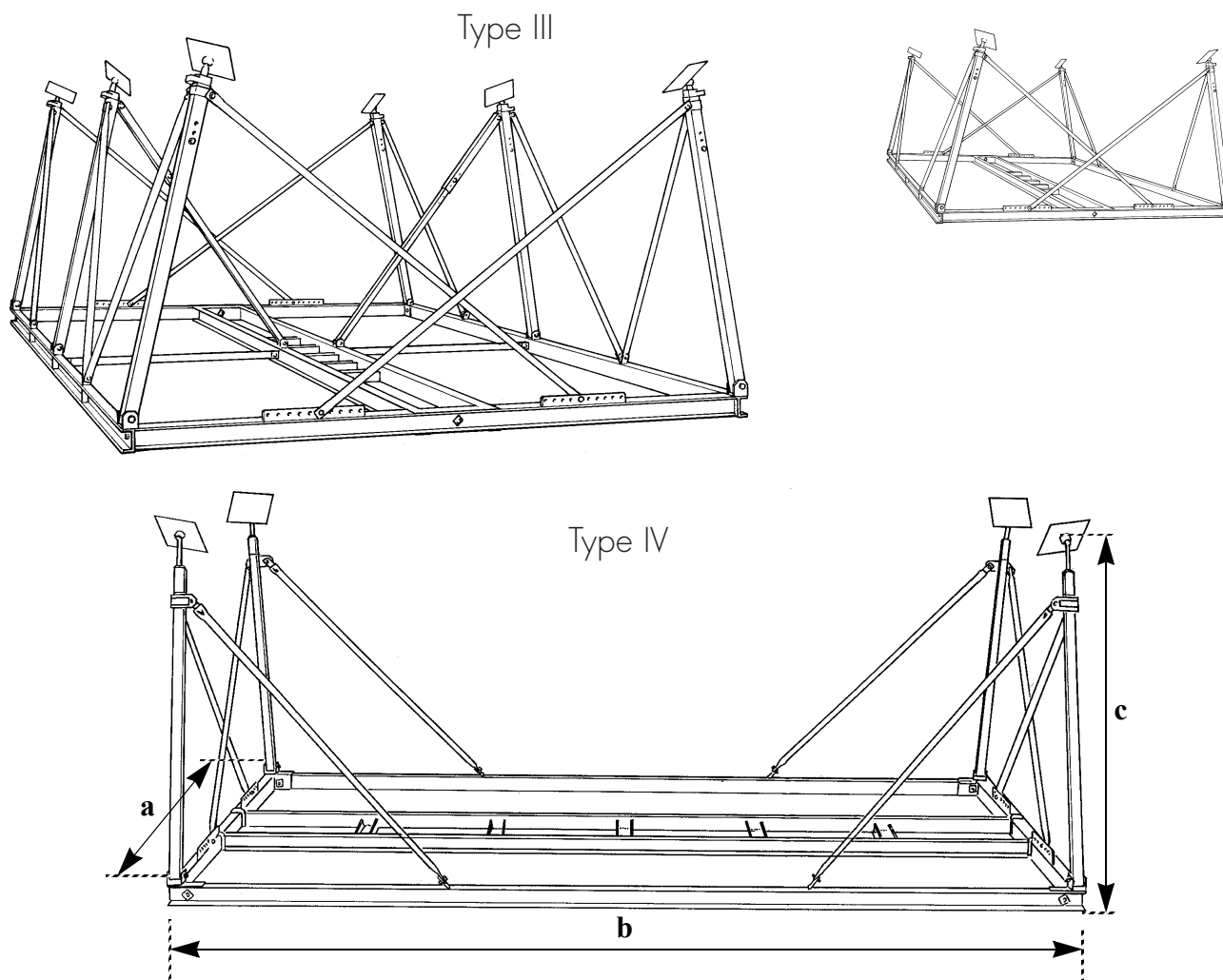

Type	Max load (kg)	Stands (No. of)	Width (a) (m)	Length (b) (m)	Stand Height (c) (approx. m)	Weight (approx. kg)
IV	10000	4	3,0	4,0	1,15-1,65/ 1,45-1,95/	250
Extension kit IV		+2	3,0	+2,0	1,75-2,25/ 1,95-2,45	80
III	15000	4	3,0	4,0	1,2-1,9/ 1,5-2,1/ 1,8-2,4/ 2,1-2,7	330
			3,0			5,0
			4,0	6,0		
			3,0			6,0
	4,0	6	5,0	405		
	3,0			6,0		410
	4,0		6,0			425
	3,0			440		
4,0	455					

Type I, II and IV can be delivered in width 2,60 m.

Recommendations:

The length of the cradle should be approximately 1/3 of the length of the boat.
Motorsailers may need stanchions with specially adapted height.

For extra stability for boats with heavy stern/aft, use the extension kit
(maximum 2 per cradle).

If in doubt – consult the manufacturer.

Cradle				Boat				
Type	Length (m)	Width (m)	Stands (No. of)	Keel type	Length (m)	Width (m)	Draught (m)	Weight (ton)
I	2,5	2,2	4	fin/long	max 8	max 3,5	1,0–1,6	max 7
	3,0				8–10			
	4,0				10–12			
II	3,0	2,2	4	fin	8–10	max 3,5	1,6–1,9	max 7
	4,0				10–12			
IV	4,0	3,0	4	fin/long	10–13	3,5–4,5	1,2–2,2	max 10
III	4,0	3,0	4	fin/long	10–12	3,5–4,5	1,2–2,75	max 15
	5,0	3,0			12–15	3,5–4,5		
		4,0				4,5–5,5		
	6,0	3,0			15–18	3,5–4,5		
		4,0	4,5–5,5					
	5,0	3,0	6		12–15	3,5–4,5		max 20
		4,0				4,5–5,5		
	6,0	3,0			15–18	3,5–4,5		
4,0		4,5–5,5						

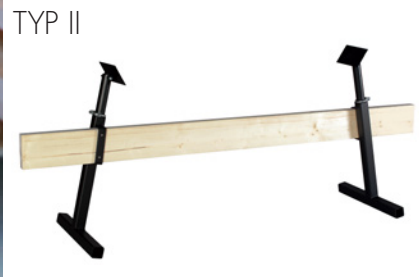



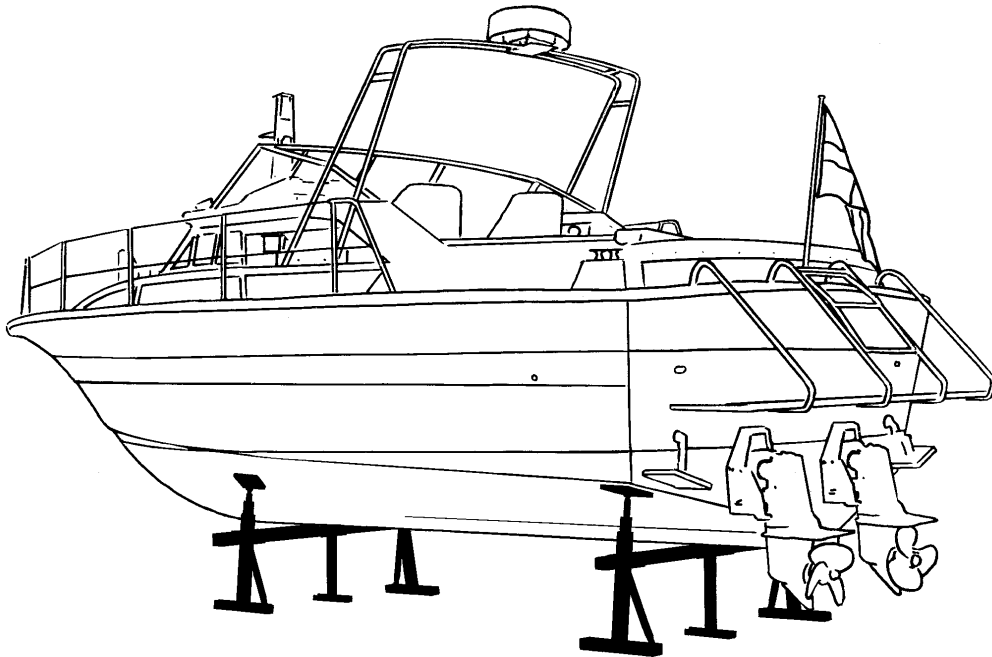

An all-steel bar stand suitable for almost all kinds of motorboats. A variety of models are available to carry loads of 500–10.000 kg each.

- **Carry heavy load compared to the weight of the bar stand itself**
- **Designed for high stability**
- **Easy to dismantle for storage to transportation**
- **Telescopic stands with accurate setting of height**
- **Ball jointed hull plates (rubber hull protection is not included)**
- **Adjustable width**
- **All parts are powder coated**

Customized bar stands are produced in accordance with individual desires.

Rubber hull protection as accessory.



210x210x25 mm
8,3x8,3x0,98 inch
TYPE I, IV, V

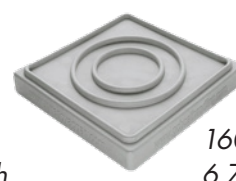

160x160x25 mm
6,7x6,7x0,98 inch
TYPE 1500

SteelBarStand/TYRESÖBOKEN

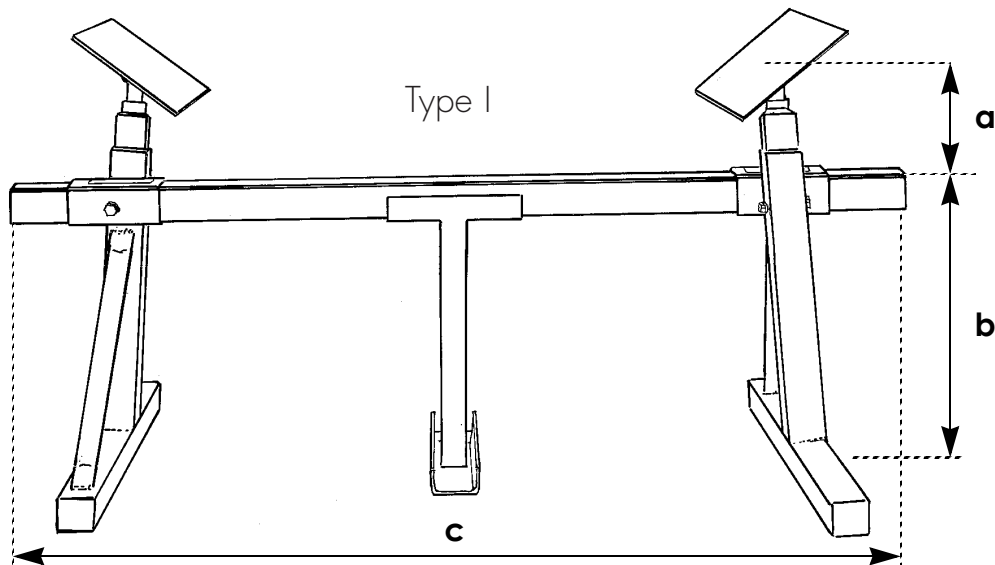
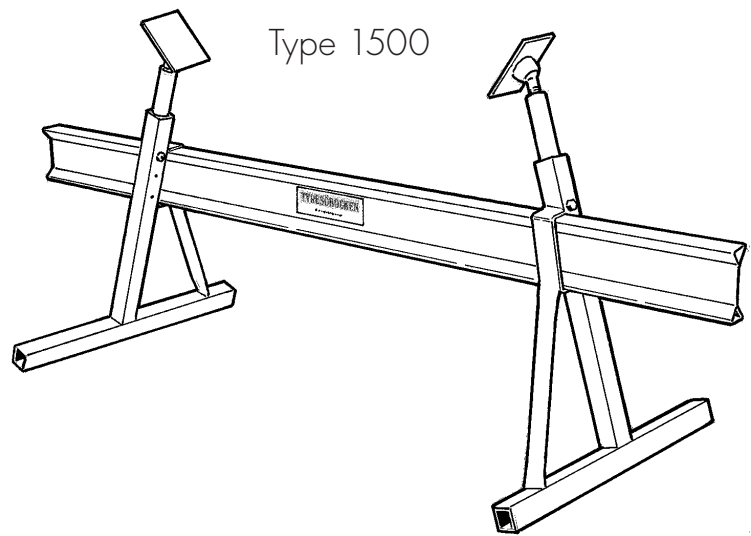
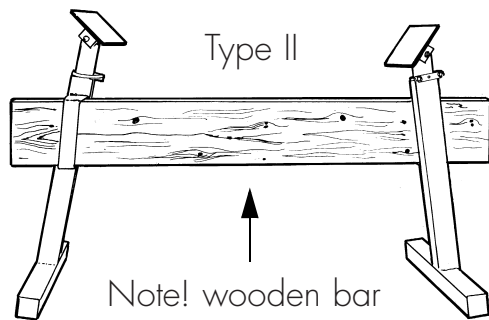

Type	Max load (kg)	Height stand (a) (m)	Height bar (b) (m)	Width (c) (m)	Weight (approx. kg)
II	500	0,1–0,45	0,5	2,0	14
1500	1500	0,2–0,65	0,6	2,0	34
I	5000	0,2–0,7	0,6	2,0	50
				2,5	54
				3,0	57

SteelBarStand/TYRESÖBOCKEN

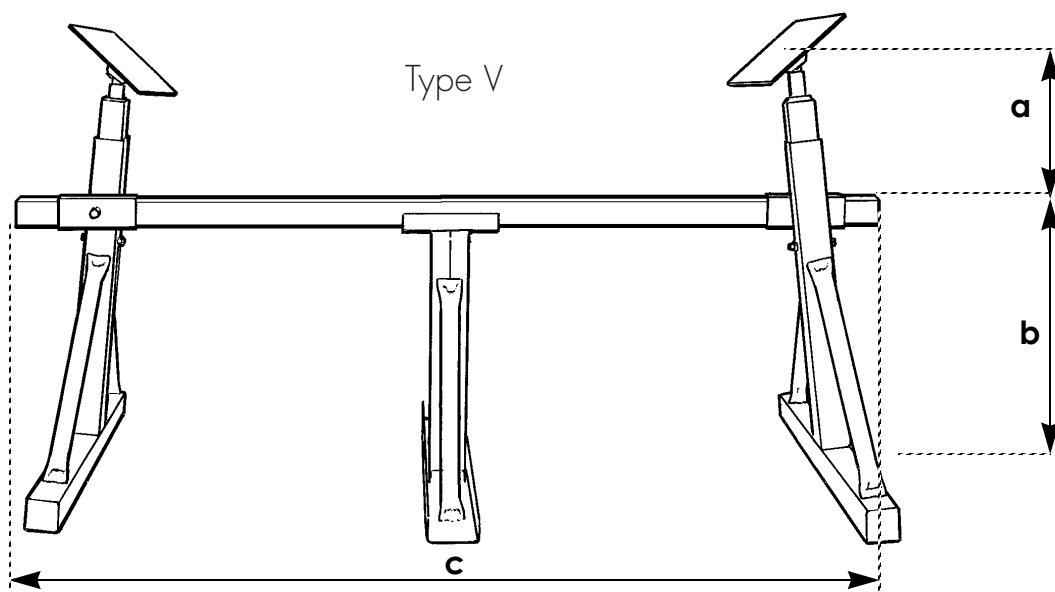
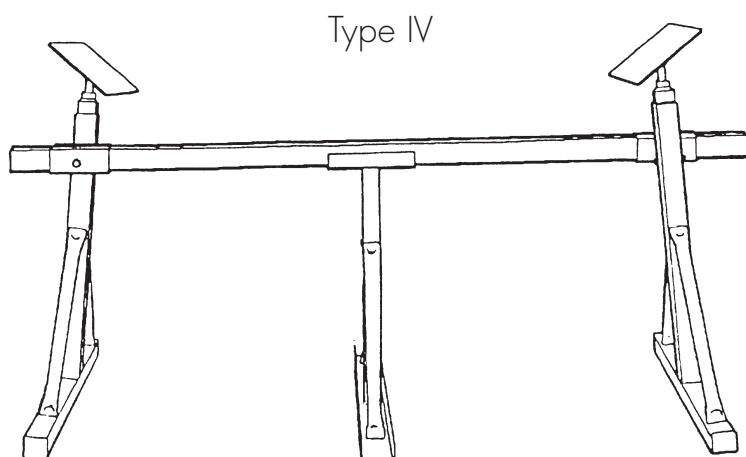

Type	Max load (kg)	Height stand (a) (m)	Height bar (b) (m)	Width (c) (m)	Weight (approx. kg)
IV	5000	0,2–0,85	0,75	2,5	80
				3,0	84
				3,5	87
				4,0	91
V	10000	0,4–1,05	0,75	3,0	110
				3,5	114
				4,0	118
				5,0	126
Keel Stand	5000	0,50–0,65	–	–	20

General recommendations:

The choice of bar stand size should be based on the total weight of the boat and on the weight distribution. Be sure to find out where the engine is placed.

Boats with AQ installations are always stern-heavy. For single engine installations the weight distribution should be approximately 30/70 (stem/stern) as a rough estimation.

Outboard motorboats tend to have a slightly better weight distribution since the motor is not usually as heavy as a corresponding AQ.

Note! The weight of the boat must include fuel, (water), supplementary equipment etc. Boat builders generally specify the weight of an empty boat. A fully equipped boat is approximately 20% heavier. (2,5 ton = 3,0 ton)

When jacking up the boat 2 stands are always needed (bow + stern) The width of the bar stand should be about equal to the beam of the boat.

If in doubt – consult the manufacturer.

Type of BarStand (Bow + Stern)		Weight distribution stem/stern (%)	Total weight (ton)
Bow	Stern		
Type II	Type II	30/70	max 0,7
Type II	Type II	50/50	max 1,0
Type 1500	Type 1500	30/70	max 2,0
Type 1500	Type 1500	50/50	max 3,0
Type 1500	Type I	30/70	max 4,0
Type I	Type I	50/50	max 10
Type IV	Type IV	50/50	max 10
Type IV	Type V	30/70	max 15
Type V	Type V	50/50	max 20





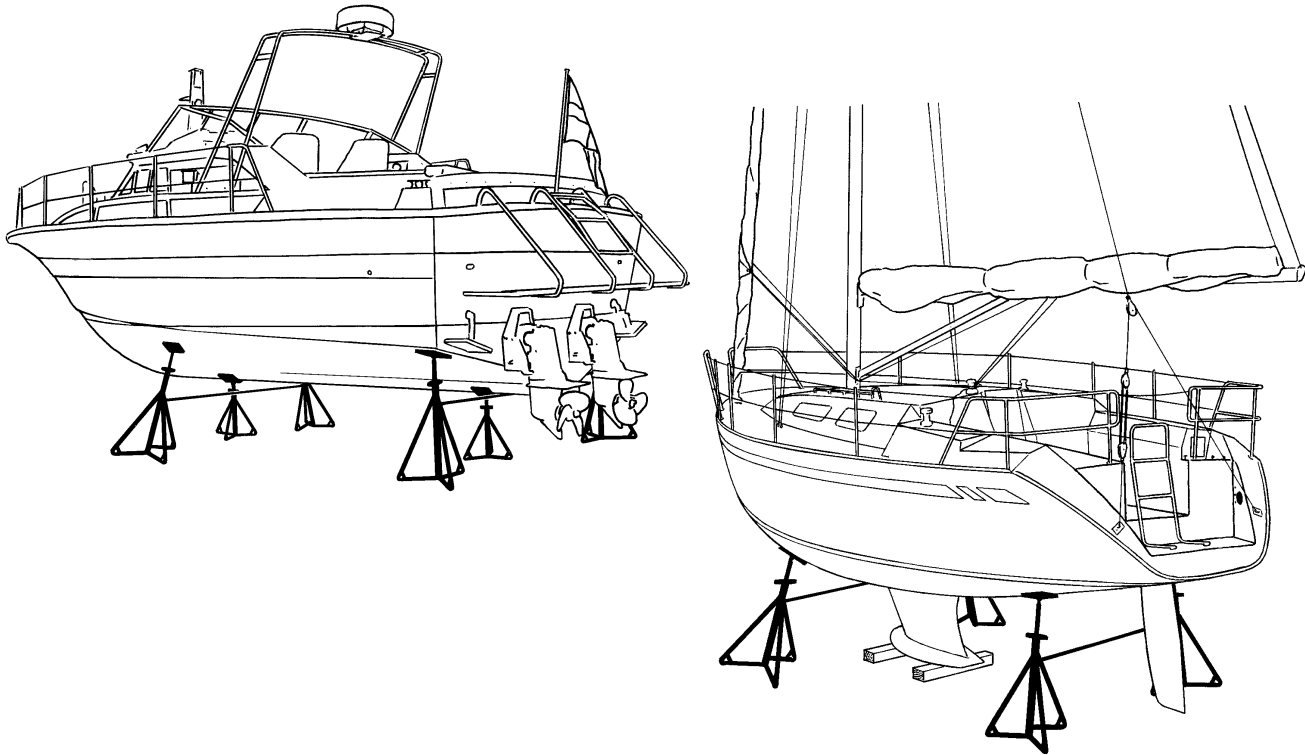

An all-steel stand suitable for boats of max 18 meter length overall. A variety of models are available to fit every kind of boat.

The steel stand is intended for clubs, marinas and boatyards at locations with good ground conditions, where the outstanding safety of the G-C SteelCradle with its very stable bottom frame and keel ladder is not necessarily required.

- **Very easy to dismantle for storage or transportation**
- **Quick height adjustment (winged nut and trapezoidal thread)**
- **Large pivoted and rubber-padded hull plate**
- **All parts are powder coated**
- **Requires only a minimum of storage space during the sailing season**

Customized stands are produced in accordance with individual desires.

SteelStand/TYRESÖSTÖTTAN

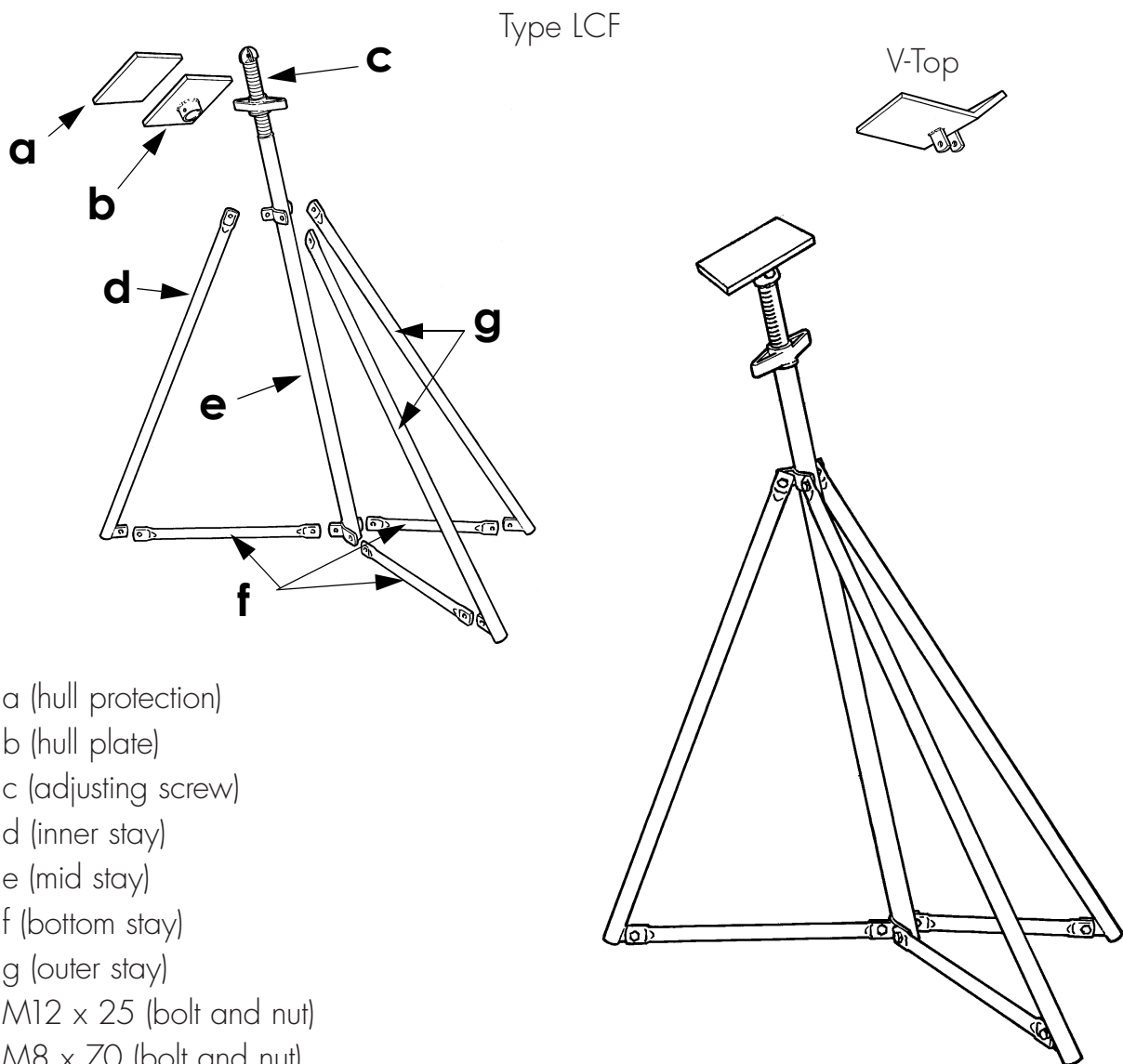

- 1 x a (hull protection)
- 1 x b (hull plate)
- 1 x c (adjusting screw)
- 1 x d (inner stay)
- 1 x e (mid stay)
- 3 x f (bottom stay)
- 2 x g (outer stay)
- 9 x M12 x 25 (bolt and nut)
- 1 x M8 x 70 (bolt and nut)
- 1 x lashing per pair of stands

Type	Max load (kg)	Height (mm)		Weight (approx. kg)
		min	max	
LCF 80	1250	800	1250	16
LCF 110		1100	1550	19
LCF 130		1300	1750	22
LCF 150		1500	1950	25
LCF 170		1700	2150	30
LCF 190		1900	2350	35
V-top				2

SteelStand/TYRESÖSTÖTTAN

Typ LCM

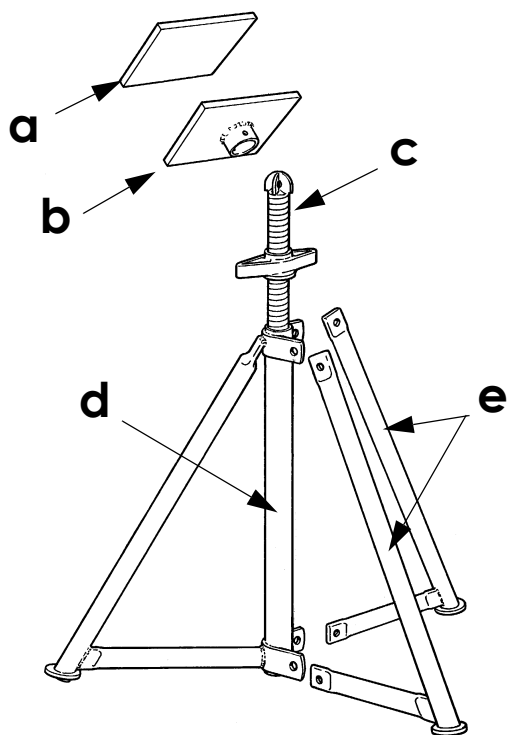

V-Top

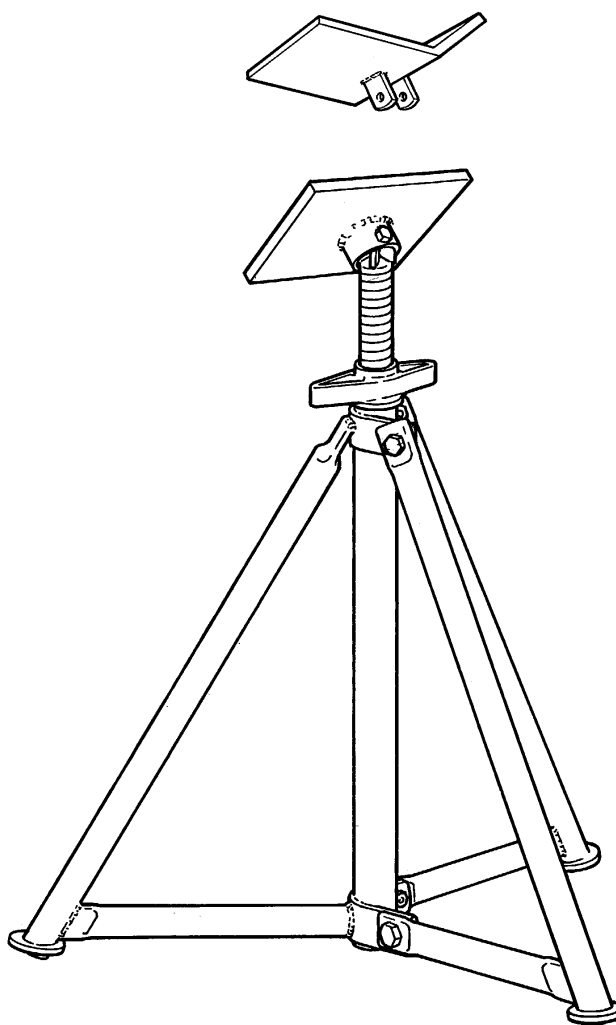

- 1 x a (hull protection)
- 1 x b (hull plate)
- 1 x c (adjusting screw)
- 1 x d (inner stay)
- 1 x e (mid stay)
- 9 x M12 x 25 (bolt and nut)
- 1 x M8 x 70 (bolt and nut)

Type	Max load (kg)	Height (mm)		Weight (approx. kg)
		min	max	
LCM 500	2500	500	800	11
LCM 600		600	900	14
LCM 750		750	1050	15
LCM 900		900	1200	17
V-Top				2

General recommendations:

Sailboats/Motorsailers: Type LCF.

Motorboats: Type LCM, (may also be combined with Type LCF).

The required number of stands depends on the weight, length and draught of the boat. The height of Type LCM stand depends on the hauling and launching method in use, which determines the necessary height of the keel above ground. The stands which support the keel need to be equipped with V-tops instead of hull plates. Two extra pairs of stands are recommended for boats with rigging.

The recommendations in the table below are based upon placement of a 0,15 metre wedge under the keel. Allow 2 stands per 2.6–3,3 m (8–10 feet). If in doubt – consult the manufacturer.

Motorboat	Sailboats/Motorsailers		# of stands	Length (m/feet)	Weight (ton)
Type		Draught (m)			
LCM	LCF				
500/ 600/ 750/ 900	80	0,8–1,25	4–6	max 9 m/29 feet	max 5
	110	1,1–1,55			
	130	1,3–1,75			
	150	1,5–1,95			
	170	1,7–2,15			
	190	1,9–2,35			
500/ 600/ 750/ 900	80	0,8–1,25	6–8	max 12 m/39 feet	max 7,5
	110	1,1–1,55			
	130	1,3–1,75			
	150	1,5–1,95			
	170	1,7–2,15			
	190	1,9–2,35			
500/ 600/ 750/ 900	80	0,8–1,25	8–10	max 15 m/49 feet	max 10
	110	1,1–1,55			
	130	1,3–1,75			
	150	1,5–1,95			
	170	1,7–2,15			
	190	1,9–2,35			
500/ 600/ 750/ 900	80	0,8–1,25	10–12	max 18 m/59 feet	max 12,5
	110	1,1–1,55			
	130	1,3–1,75			
	150	1,5–1,95			
	170	1,7–2,15			
	190	1,9–2,35			



L-Stand



Displaying

Stock your NEW outboards in a smart and practical way

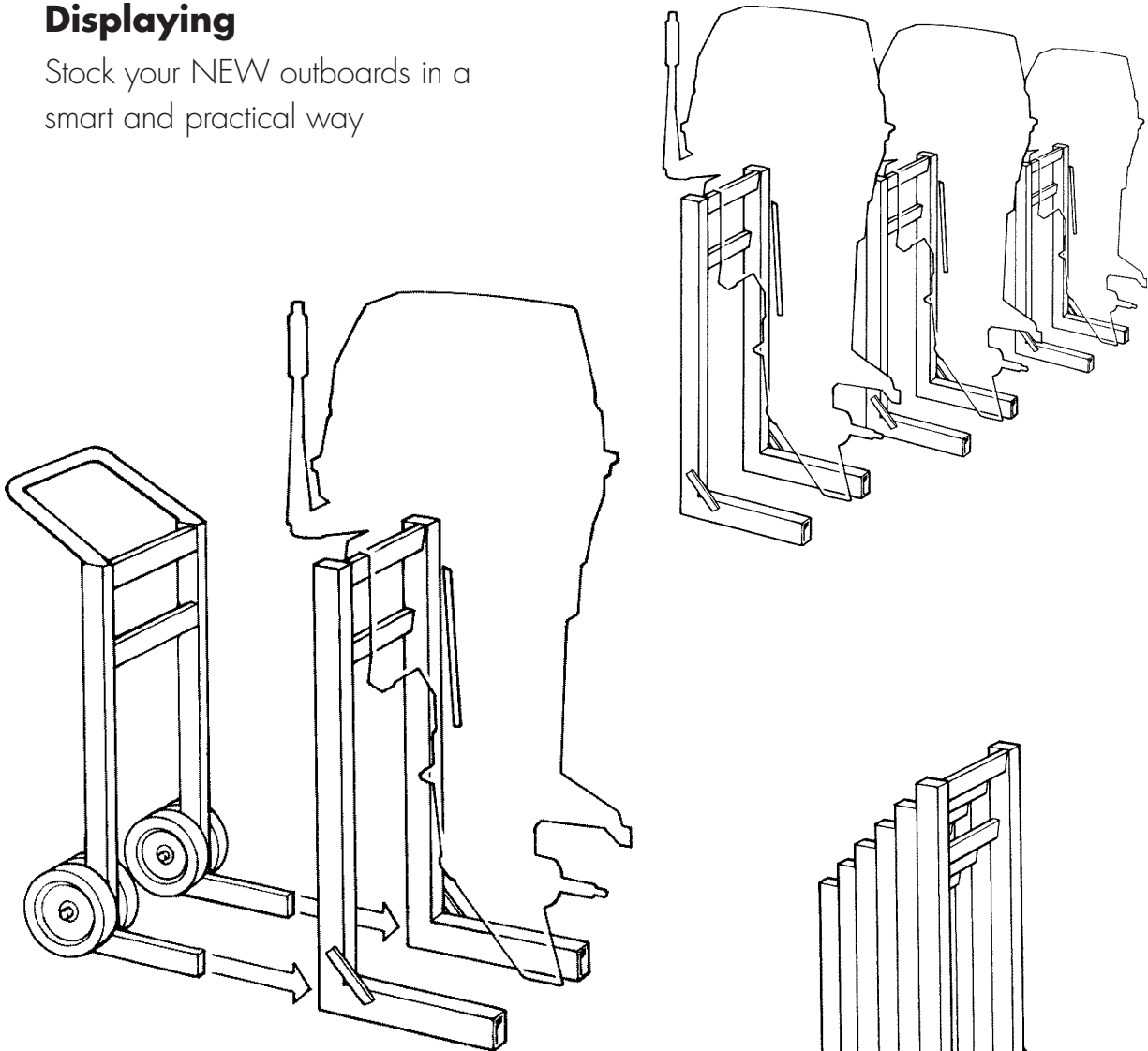

Storage

With this easy and safe system you can use the height of the walls and save expensive floor space

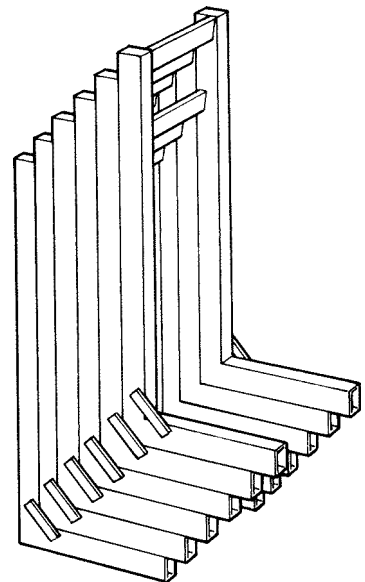

L-stand

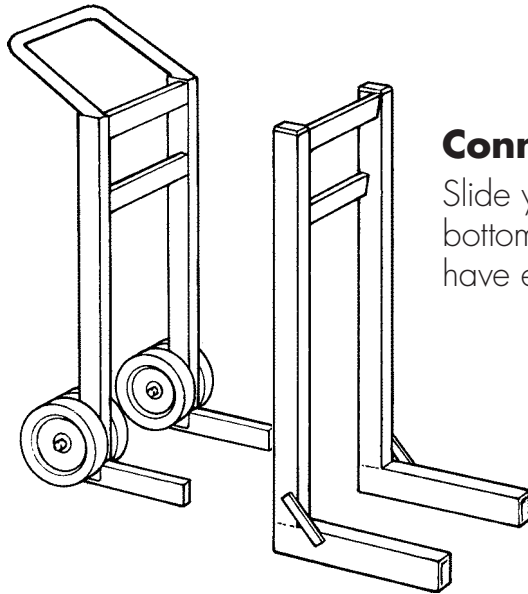

Connecting

Slide your L-Lifters forked into the bottom tubes of the **L-stand** and you have engaged the system



Lifting

With our ingenious L-Lifter you move your outboard and the **L-Stand** at the same time

- When cleaning
- Redecorating
- When delivering
- In your workshop

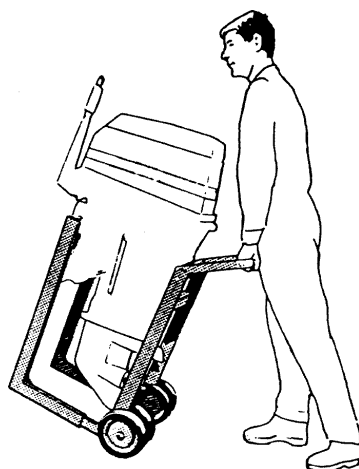

Handling

With this fantastic L-Lifter and **L-Stand** you give far better service

L-stand

Stand/Lifter

Type TLL 150/225

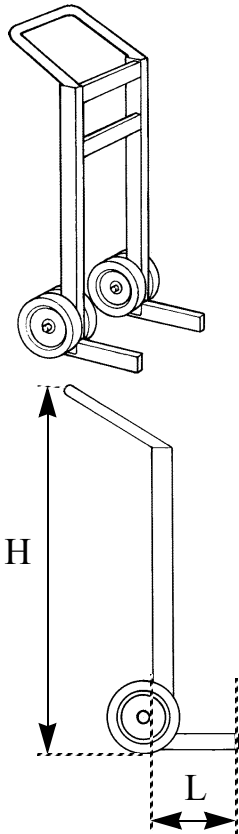

Stand

Type TLS 150/225/325

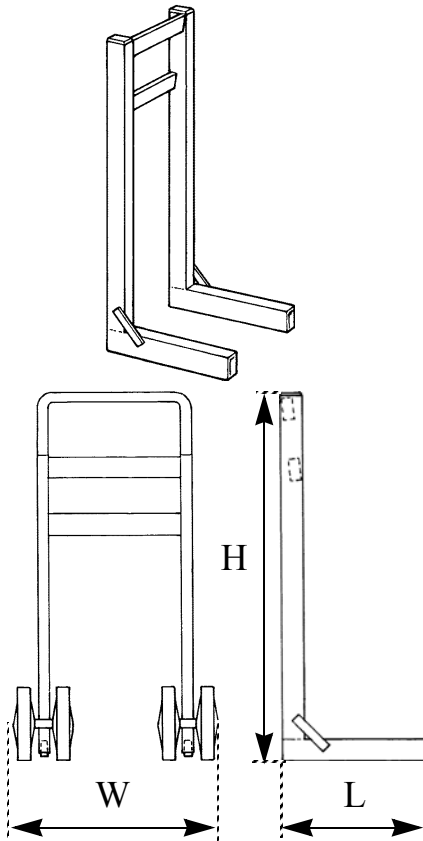

Engine/Lift

Type L 150/225

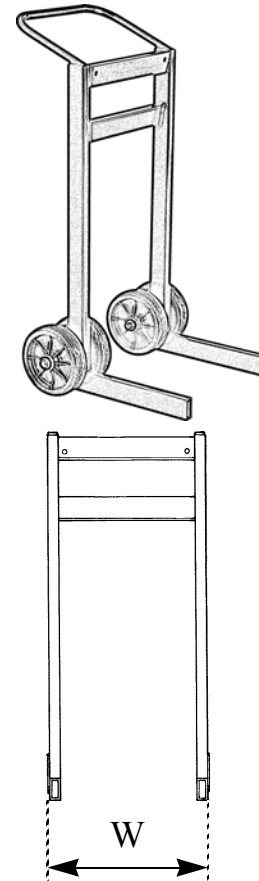

Type	Dimensions (mm)			Weight (kg)	Max load (kg)
	H	L	W		
TLL 150	850	250	600	14,5	150
TLS 150	910	400	435	9	
L 150	910	400	600	14,5	
TLL 225	900	250	725	20	225
TLS 225	960	500	535	14,5	
L 225	960	500	725	20	
TLS 325	1110	600	535	23	325
TLS 300 MEGA	850	500	2500	30	300

DATA:

Frame: Welded steel tubes

Surface finish: Powder coated (black)

Wheel: 2 double set with synthetic rims and rubber tyres



G-C Stern Drive Stand



The **G-C STERN DRIVE STAND** (DL 150) is an unique product for easy handling and servicing your sterndrive. This light weight product is an innovation because it will make it easier to handle, transport and store your heavy sterndrive. Made of strong steel and finished with an indestructable powder coated paint. Delivered complete with two straps and rubber strips for protection.

For easy transport of multiple **STERN DRIVE STANDS** without plastic wheels (DLS 150), you can use the G-C lifter TLL 150.

- Easy handling sterndrive
- Easy servicing sterndrive
- Light weight (14 kg)
- Indestructable powder coated paint
- Possibility for wheels of lifter
- Max load 150 kg



DL 150



DLS 150



52x58x8 cm, weight 14 kg



TLL 150





The **G-C Trailer** is developed and constructed by professionals for boatyards and marinas. All types of boats – motor or sailing boats, regardless of hull form – can be handled. The trailer is constructed so that one person can easily handle it alone.

The **G-C Trailer** has bogie-mounted wheels that make it go steady and safely also over rough ground.

The **G-C Trailer** has a single axle design that make it easy to operate in narrow spaces both forward and backward.

The **G-C Trailer** is constructed in steel for safe, uncomplicated and long-standing use for professionals with the highest demands.

The **G-C Trailer** works together with most pallet systems but together with **SteelCradle/TYRESÖVAGGAN**, **SteelBarStand/TYRESÖBOCKEN** and **SteelStand/TYRESÖSTÖTTAN** you will have an unbeatable system.

G-C Trailer

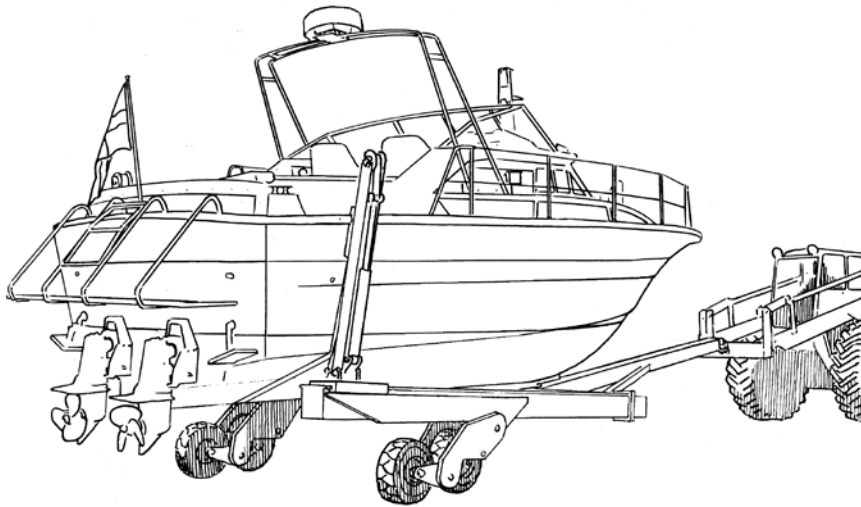

- Hydraulically adjustable width and length.
- The width is easily adjusted to the cradle you wish to straddle.
- Hydraulic belt tension and adjustment of the struts make it possible to handle all types of boats.
- The draw bar is adjustable in length which makes the handling on a ramp easier as well as to operate in narrow spaces.
- All surfaces that are in direct contact with the boat are protected to avoid scratches or other damages. In protection of the boat hull, a 150 mm wide shoulder harness with a detachable C-clamp is used.

If you need further information, do not hesitate to contact us.

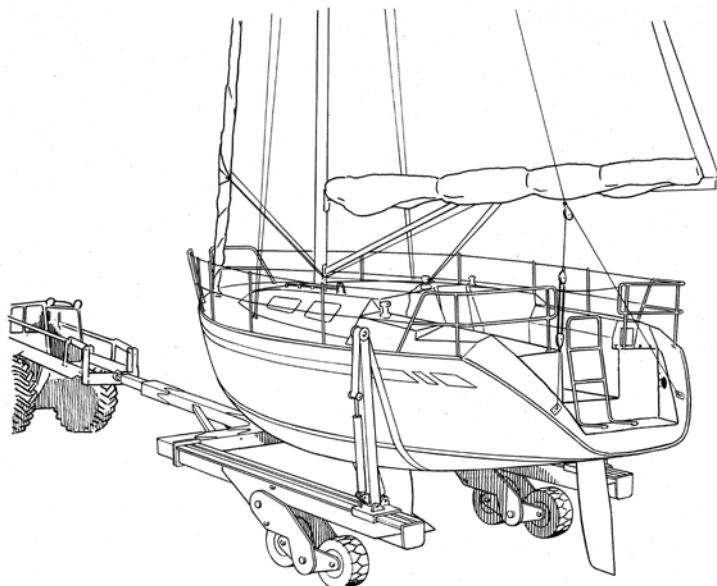

G-C Trailer

Max load	15 tons
Frame height (A)	0.7–1.5 m
Frame length (B)	5.0 m
Width (inside) (C)	2.4–3.2 m
Adjustable draw bar (D)	>1.8 m (4.0–5.8 m)
Hydraulically adjustable stem plate (E)	1.0 m
Total length t (trailer + drawbar)	9.5–11.0 m
Angulation struts (F)	$\pm 15^\circ$
Band sling with divisible C-shaped shackle (G)	± 4.0 m
Material/surface treatment	Hot-dip galvanized steel, all shafts in stainless

The boat rests on the adjustable stem plate and a band sling at the rear.

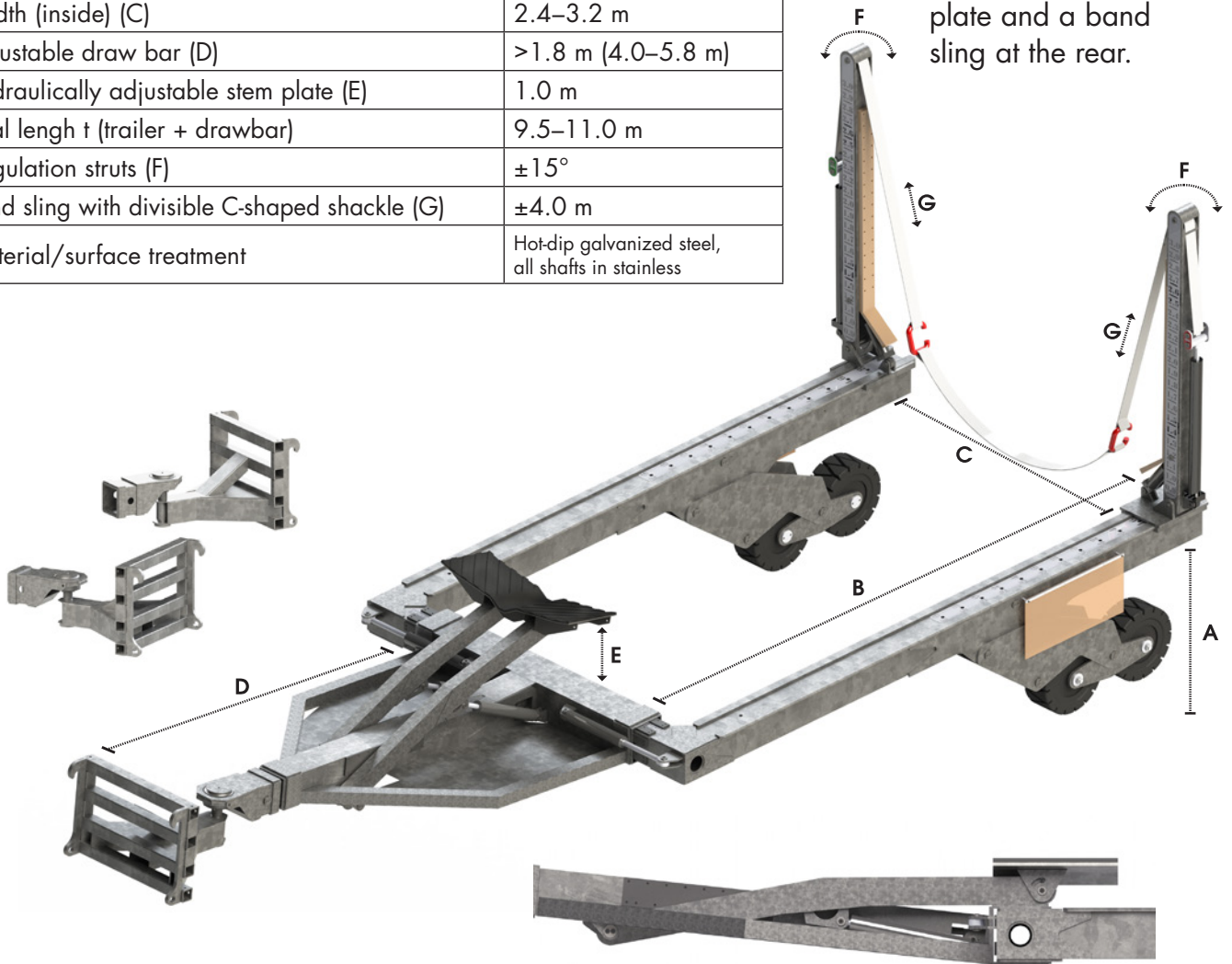

Hydraulically adjustable stem plate.

Lift sling
(Maximum load 1 ton)

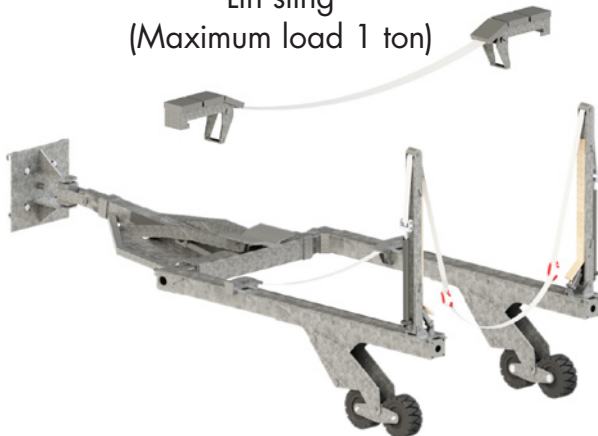

The boat rests on front and rear sling (only for smaller/lightweight boats).

Lift brackets

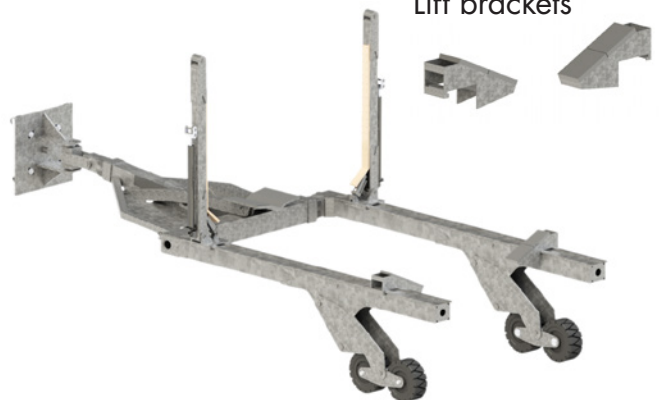

The boat rests on a stem plate and lift brackets (for hulls with sharp angles).

TECHNICAL DATA

Weight	CE-signed Approximately 4,5 tons
Maximum load	15,0 tons
Allocation of weight	5 tons stem plate + 5 tons bogie
Lifting height, bogie	Approximately 0,8 m (hydraulically operated)
Widening	Approximately 0,8 m (hydraulically operated)
Adjustment of draw bar	Approximately 1,8 m (hydraulically operated)
Stem plate (adjustment in height)	Approximately 1,0 m (hydraulically operated)
Hydraulic system	Radio operated
Working pressure	170–200 Bar
Valves	Ratio controlled
Belt	Divisible with C-shackle
Tension	Approximately 4,0 m (hydraulically operated)
Width	150 mm
Frame	
Quality of material	S355 J2H
Strength	FEM Analysis
Rust protection	Galvanized
Wheels/rims	
Type	Massive/soft, puncture protected
Dimension	23x9–10
Number of wheels	4
Maximum load per wheel	3,5 tons
Cylinders	
Material	Piston rod, stainless, AISI 329
Rust protection	Meets C4
Safety	Hydraulic locks on all load-carrying cylinders
Shafts	
Material	Stainless

With reservations for changes in construction.

All the material used in **G-C Trailer** is chosen to guarantee minimal maintenance and high security in combination with the best functionality. A quality product with the longest life span.

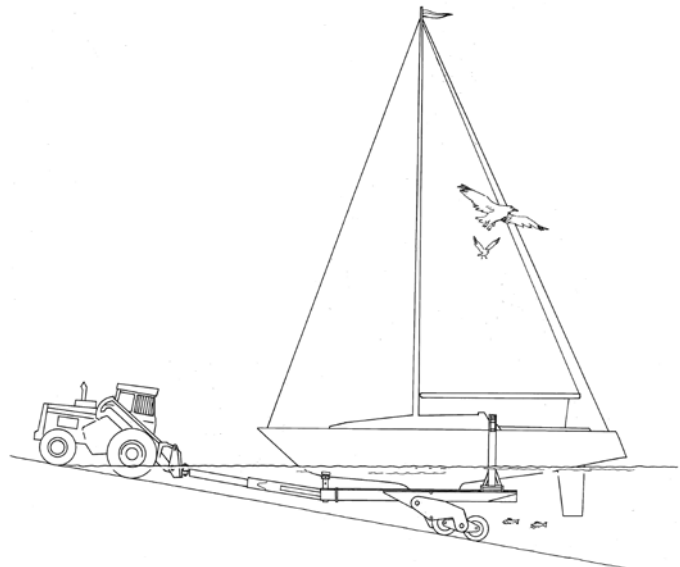

Mast crane



**CE-standard. Lifting height ca 12–15 m.
Max load 500 kg. Hot dipped.**



Reseller/Shop

SWEDEN

BYGGPLAST & BÅTPRYLAR

Wholesale/Distributor
1500 reseller
www.byggplast-batprylar.se

BENN'S MAST & BÅTTILLBEHÖR

Reseller
www.benns.se

BÅTACCENTEN

Reseller
www.bataccenten.se

ERLANDSONS BRYGGA

Reseller
5 stores
www.erlandsonsbygga.se

HJERTMANS

Reseller
9 stores
www.hjertmans.se

SEASEA

Reseller
30 stores
www.seasea.se

AUSTRIA

A.W. NIEMEYER

Reseller
1 store, Online Shop
www.awn.de

CROATIA

ADVENTURE NAUTIC SHOP

Distributor/Reseller
www.adventure-charter.hr

DANMARK

DANCOVER A/S

Reseller
Reseller in Europe, 17 countries
www.dancover.com

HJERTMANS DANSK MARINEUDSTYR

Reseller
www.hjertmans.dk

ESTONIA

SEAWAY CLOTHING OÜ

Reseller
www.seawayclothing.ee

FINLAND

OY VESTEK AB

Reseller
Wholesale/Distributor
50 reseller, 4 stores
www.vestek.fi

MOTONET OY

Reseller
34 stores
www.motonet.fi

DUELL BIKE-CENTER OY

Wholesale/Distributor
www.duell.fi

GERMANY

A.W. NIEMEYER

Reseller
7 stores, Online Shop
www.awn.de

ACKERMANN

YACHTHAFENAUSRÜSTUNG E. K.
Reseller
www.ackermann-bootsstege.de

OUTMAR

Online Shop
www.outmar.com

LATVIA

BALTIJAS JAHTU SERVISS SIA

Reseller
www.laivulietas.lv

MONTENEGRO

ADVENTURE NAUTIC SHOP

Distributor/Reseller
www.adventure-charter.hr

NEDERLANDS

XL MARINE

Reseller
www.xlmarine.eu

EUROPA

IMDS

Distributor
www.imds.eu

NORWAY

SEASEA

Reseller
2 stores
www.seasea.no

NORWAY MARINE SUPPLY AS

Wholesale/Distributor
1200 reseller
www.nmsinfo.no

MARITIM BÅTUTSTYR

Reseller
6 stores
www.maritim.no

SLOVENIA

ADVENTURE NAUTIC SHOP

Distributor/Reseller
www.adventure-charter.hr

SWITZERLAND

A.W. NIEMEYER

Reseller
1 store, Online Shop
www.awn.de

SUTER MARINE DÜBENDORF

Wholesale/Reseller
www.suter-marine.ch

USA/NORTH AMERICA

SCAFFOLDMART

Distributor
www.scaffoldmart.com



RESELLER



Maskinfabriken G-C A.B.

Thulevägen 18, S-135 55 TYRESÖ
Tfn. +46 8 712 50 90. Fax. +46 8 712 71 90
info@gcboathandling.com www.gcboathandling.com
info@tyresovaggan.com www.tyresovaggan.com

